

The Seakeeper 3 is designed to eliminate up to 95% of boat roll on recreational vessels ~36 to 39 feet (11-11.8 meters) or up to ~10.5 tons. It runs exclusively on 12V DC power, has no outside appendages and can be installed virtually anywhere on board.

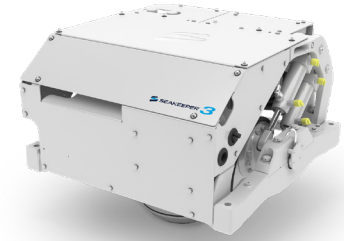

## TECH SPECS

<b>Rated Speed</b>	8,450 RPM
<b>Angular Momentum at Rated RPM</b>	3,000 N-M-S
<b>Max Anti-Rolling Torque at Rated RPM</b>	7,854 N-M
<b>Spool-up Time to Rated RPM</b>	50 minutes (8,450 RPM)
<b>Spool-up Time to Stabilization</b>	36 minutes (7,185 RPM)
<b>DC Input Voltage</b>	12 VDC @ 85 Amps
<b>Spool-up Power</b>	
DC	900 Watts Max
<b>Operating Power</b>	
DC	400 - 750 Watts (Sea State Dependent)
<b>Sea Water Supply to Heat Exchanger</b>	2 - 6 Gal/Min.
<b>Ambient Air Temperature</b>	0° - 60° C (32° - 122° F)
<b>Weight</b>	550 lbs (249 kg)
<b>Envelope Dimensions</b>	Length x Width x Height 26.8 L x 27.0 W x 22.5 H (Inches) 0.681 L x 0.686 W x 0.572 H (Meters)
<b>Noise Output</b>	<72 dBC at 1 meter

## PORT VIEW

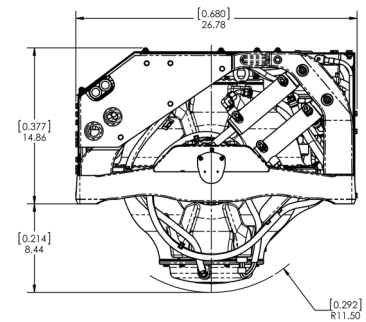

## FRONT VIEW

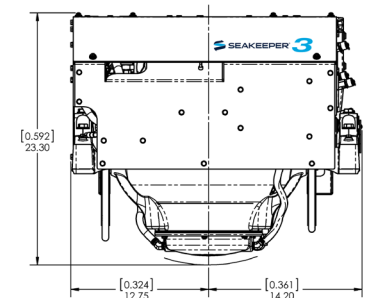

## TOP VIEW

